

H. WATERS.

Improvement in Lathes for Cutting Grooves in Metal Rollers.

No. 115,000.

Patented May 16, 1871.

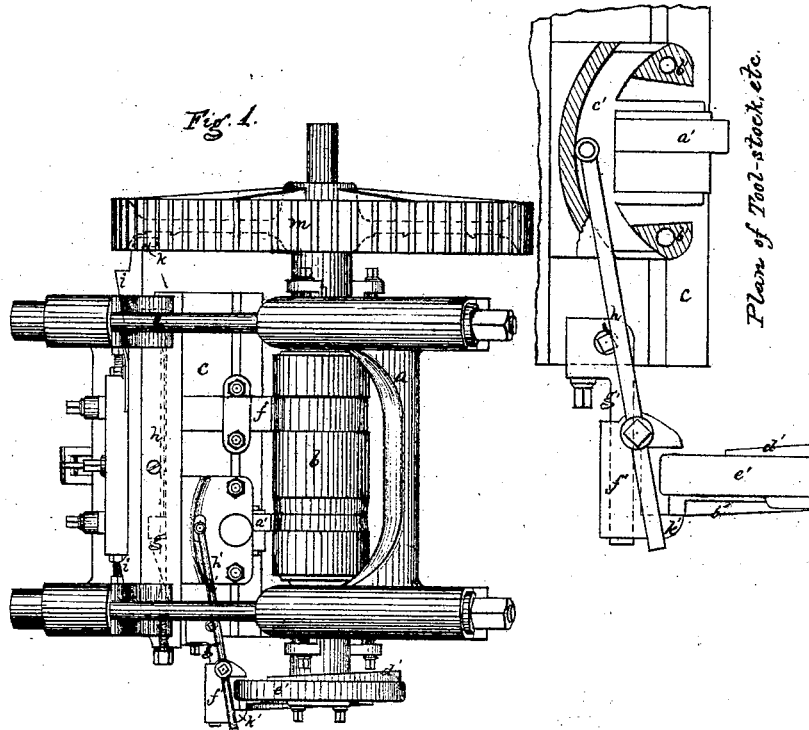
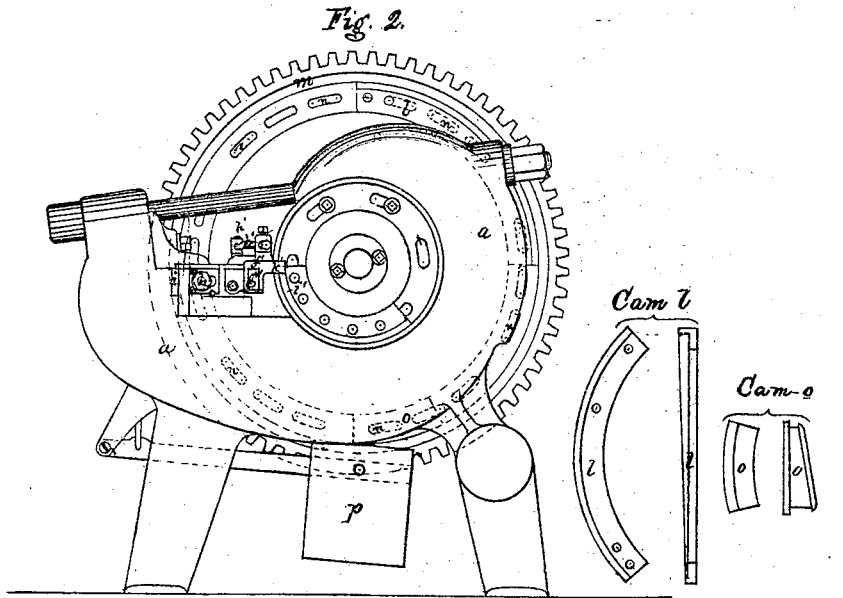

Witnesses
S. B. Hilder.
Ch. W. Frothingham.

Henry Waters
by his atty
Crosby, Halsey & Gould

UNITED STATES PATENT OFFICE.

HERVEY WATERS, OF BOSTON, MASSACHUSETTS.

IMPROVEMENT IN LATHES FOR CUTTING GROOVES IN METAL ROLLERS.

Specification forming part of Letters Patent No. 115,000, dated May 16, 1871.

To all whom it may concern:

Be it known that I, HERVEY WATERS, of Boston, in the county of Suffolk and State of Massachusetts, have invented an Improvement in Die-Roll Lathes; and I do hereby declare that the following, taken in connection with the drawing which accompanies and forms part of this specification, is a description of my invention sufficient to enable those skilled in the art to practice it.

My invention relates to the organization, arrangement, and mode of operation of mechanism for turning and shaping grooves in die-rolls for rolling metals. More particularly in the machinery herein specifically described the improvements have reference to cutting-dies in the working-surfaces of rolls to be employed in a rolling-mill for rolling knife-blades, though the improvements are applicable to other similar purposes.

The invention consists in combining with a roll-lathe and its cutting-tool a mechanism for automatically moving up and back the tool-rest with its tool by means of two wedges working simultaneously upon the two ends of the rest, the rest being further provided with means for forcing the tool to its work at the will of the operator as the cutting progresses.

The invention also consists in combining with the said lathe a mechanism for swinging the cutting-face of the tool during its cutting action upon the roll—in this instance in such a manner that while one corner of the tool cuts deeper and deeper, the other corner cuts concentrically, the cutting-face between, of course, varying from the uniform depth of one side to the greatest depth effected by the other side of the tool.

The drawing represents a lathe mechanism embodying my improvements.

Figure 1 shows the machine in plan. Fig. 2 is an end elevation of it.

a denotes the main frame of the machine, in which the roll *b* is mounted and turns in suitable bearings, with shoulders or other equivalent device to prevent end movement of the roll. *c* denotes the tool-rest; *f*, a tool the face of which is straight and parallel to the axis of the roll, which parallelism it keeps during the rotation of the roll, and while it has a forward motion, so as to cut the die-groove in the work-

ing-face of the roll gradually deeper from beginning to end of the working-groove. This progressive or forward movement is produced as follows: The tool-rest has a bearing at each end upon the main frame, and is made in two parts, the part carrying the tool sliding upon the other part and upon the frame by means of wedges *g g*, attached to a rod, *h*, which is moved endwise by a screw and nut upon one end. The other part of the rest bears against a friction-plate, which bears against wedges *i i*, which bear against shoulders upon the main frame.

At one end of the wedges is a projection, *k*, against which acts a cam, *l*, on the driving-wheel *m* on the end of one of the roller-necks. This cam is adjustably fixed to the wheel by screw-bolts passing through slots *n*, and when set so that it starts the wedges as the working-surface of the roll comes opposite the cutting-edge of the tool, such edge being against the roll, it moves the wedges endwise and the tool forward as the roll turns, in accordance with the eccentric form to which the die-groove is to be cut. The wedges are drawn back by another cam, *o*, acting upon the hooked end of the projection *k*, and as they slide back the tool-rest is returned to normal position by the action of the weight *p*, or a spring, or any other suitable device.

In turning the groove for the handle-plate attached to the end of a knife-blade, the cam is set so that the tool begins to cut near the front working end of the groove or working-surface of the roll. Then, as the work progresses, the tool-supporting part of the rest is fed up by means of the screw-rod *h* and nut, which operate the two inclines or wedges *g g*, attached to the rod, and feed the tool-supporting part of the rest forward as the nut is turned, so that the depth of cut and length of the groove may be gradually increased until the whole groove is turned as desired, the cam *l* and wedges *i i* effecting the taper or eccentricity of the groove, and the feed or progression of the tool being effected by the screw-rod *h* and inclines or wedges *g*.

The tool *f* may be first used without the cams, and the groove cut concentrically to the mean depth required by gradually feeding up the tool-supporting part of the rest by the nut

and rod *h* and wedges *g g*, the cams being then applied and the groove cut to the desired eccentric form.

For turning an irregular eccentric groove for a knife-blade I work a tool, *a'*, as follows: The tool is mounted in a holder, *b'*, clamped to the rest, and in this holder is a tool-stock, *c'*, which is fitted to slide in a circular groove or guideways, the movement of the tool-stock being circular and concentric to one corner of the cutting-edge of the tool. This movement of the tool is effected by a cam, *d'*, on a wheel, *e'*, fixed on one of the roller-necks operating against a projection from a slide, *f'*, mounted on an arm, *g'*, projecting from the end of the rest, the slide being connected to the tool-stock by a rod, *h'*, jointed at one end to a pin projecting from the tool-stock, and fixed at the other end to a pin turning in the slide, the end movement of the slide transmitting similar movement to the tool-stock, as will be readily understood.

Backward-swinging movement of the tool is effected, when the open part of the roll is passing it, by a cam, *i'*, on the outer side of the wheel, which acts upon a projection, *l'*, from the slide *f'*.

The groove shown in the drawing is formed for rolling two knife-blade blanks, or rather a blank for two knife-blades, side by side, the material for the backs of the two blades being at the center of the blank. The tool, therefore, first forms one-half of the groove, and is then shifted to the other side of the holder, (it being kept in place in the holder in each instance by suitable keys,) and the tool-rod, cams, and slide being properly adjusted, the tool will work the same as before, but conversely.

In using the cutting-tool *a'*, it may at first

be worked without the cams by disconnecting the rod *h'*, cutting the groove concentrically to the depth and form desired for the point end of the knife-blade by gradually feeding up the tool-supporting part of the rest, as before described, the rod being then connected and the tool being retracted to such position as to allow it to pass the working-face of the roll, or so far as to make a single cut at the extreme inward swing of the tool, and then feeding up the tool, as before described, until the desired length of groove is obtained, one side of said groove giving the desired lateral form to the edge of the blade, and the other the desired lateral form to the back of the blade, the cross form of every cross-section of the blade being determined by the form of the face of the tool and its inclination to the axis of the roller.

I claim—

1. In combination with a roll-lathe and its cutting-tool, and with means for feeding the tool to its work as the cutting progresses, mechanism for automatically moving the tool-rest up and back with its tool by means of two wedges working simultaneously upon the opposite ends of the rest, when such mechanism is constructed and operates substantially as described.

2. The combination, with a roll-lathe and its tool, of a mechanism for automatically swinging the cutting-face of the tool during its cutting action upon the roll, when such mechanism is constructed and operates substantially as described.

HERVEY WATERS.

Witnesses:

J. B. CROSBY,
FRANCIS GOULD.